

SRJ

SRJ is an electric actuator that can use AC110V/220V single-phase and 220V/440V three-phase current, and is mainly suitable for valve sizes of 300A or less.

It is a completely waterproof type actuator for small rotary valves that rotate 90°. Equipped with a limit switch and torque switch as standard. It is also compatible with Exd II BT4 pressure-resistant, explosion-proof configuration.



Features

- Valve opening and closing driven by an electric motor
- Equipped with open / close torque switch as standard
- Equipped with fully closed and fully open position contact output as standard
- Completely waterproof

SRJ Specifications						
Type		SRJ-010	SRJ-020	SRJ-060	SRJ-1	SRJ-2
Output torque (Nm)		125	250	600	1000	2000
Power source		AC100V/110V, 200V/220V 50/60Hz Single-phase AC200V/220V, AC400V/440V 50/60Hz Triple-phase				
Motor capacity (W)		40	100	200		
Travel time (50/60 Hz) (sec.)	Standard time	18/15	36/30		72/60	
	Setting at time of order	9/7.5	18/15		36/30	
Mass (kg)		13	18	40		
Rating (min.)		15				
Insulation		B				
Motor protection		Thermal protector				
Stopper		Mechanical (full-closure/opening positioning bolt type)				
Position limit switch		Full-closure/opening, torque switch: one each (1a1b non-voltage)				
Torque limit switch		Contact capacity: AC250V-2A (at induction load), Contact capacity: DC125V-0.4A				
Conduit connections		G1, 3 ports				
Enclosure		IP68				
Manual operation		Reserve (round handle switching lever type auto return)				
Handle revolutions (to 90°)		20.8	26	79.4		
Coating		Lacquer primer (Munsell N7)				
Options		① Pressure-resistant, explosion-proof (ExII BT4): Except SRJ-1 and SRJ-2 ② Potentiometer (135Ω, 200Ω and 500Ω) ③ Seimitter (R/I converter) ④ Intermediate valve opening output ⑤ Intermediate valve opening seimitter (Intermediate valve opening output, Seimitter R/I converter) ⑥ Seitroller (Power: single phase only)				

SRJ Dimensions

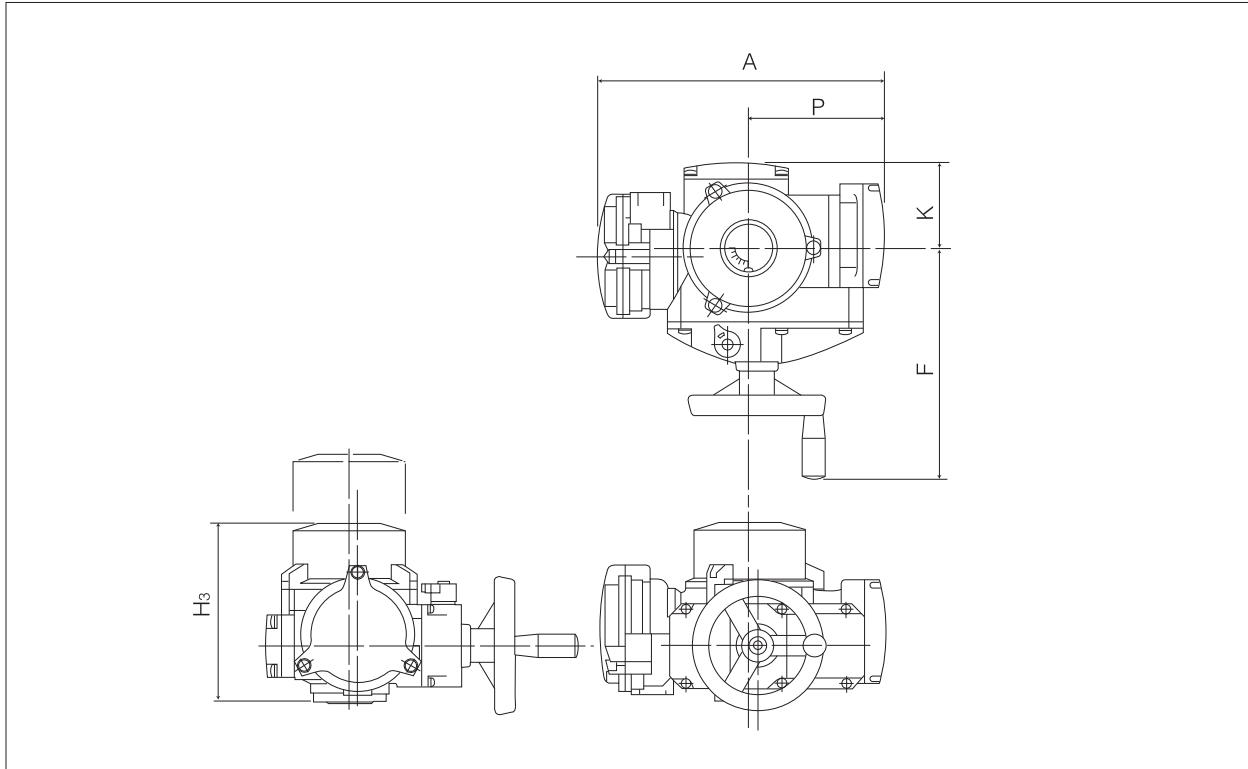

SRJ Dimensions and Weight

Type	Dimensions (mm)					Approx. Mass (kg)
	H ₃	A	P	F	K	
SRJ-010	218	353	167	272	104	13
SRJ-020	218	353	167	272	104	13
SRJ-060	235	393	191	316	130	18
SRJ-1	296	507	267	354	191	40
SRJ-2	296	507	267	354	191	40

Actuator

New ELMY
41

New MICON ELMY II
41

PMK-SRF
4K

SRJ
4J

LTKD
4L

New T-DYNAMO
7E/7F/7G

TGA
3A

TG-S
3K/3U

3C

Diaphragm
6X/6W/6Z/6A/6B

Hydraulic cylinder
3H

Manual Actuators
17/1J/2U/2I/2S/2G/2R

SRJ Motor Rated Current

Type	Power source (V)	Frequency (Hz)	Single-phase motor		Three-phase motor	
			Starting current (A)	Rated current (A)	Starting current (A)	Rated current (A)
SRJ-010 SRJ-020	100	50	2.31	1.40	—	—
		60	2.34	1.44	—	—
	110	50	2.61	1.73	—	—
		60	2.59	1.50	—	—
	200	50	1.20	0.72	1.27	0.53
		60	1.19	0.78	1.19	0.45
	220	50	1.34	0.88	1.40	0.59
		60	1.33	0.80	1.28	0.48
	400	50	—	—	0.63	0.26
		60	—	—	0.58	0.22
440	50	—	—	0.68	0.29	
	60	—	—	0.63	0.23	
SRJ-060	100	50	3.25	2.44	—	—
		60	3.38	2.48	—	—
	110	50	3.60	2.74	—	—
		60	3.71	2.50	—	—
	200	50	1.86	1.56	1.89	0.74
		60	1.82	1.13	1.77	0.67
	220	50	2.04	1.84	2.00	0.76
		60	2.01	1.27	1.92	0.67
	400	50	—	—	0.94	0.37
		60	—	—	0.90	0.34
440	50	—	—	0.99	0.39	
	60	—	—	0.97	0.34	
SRJ-1 SRJ-2	100	50	9.33	4.98	—	—
		60	9.63	7.43	—	—
	110	50	10.27	5.15	—	—
		60	10.56	7.43	—	—
	200	50	4.34	2.18	4.57	1.10
		60	4.45	3.00	4.31	0.99
	220	50	4.87	2.28	5.07	1.06
		60	4.91	2.99	4.76	0.96
	400	50	—	—	2.35	0.53
		60	—	—	2.24	0.48
440	50	—	—	2.48	0.52	
	60	—	—	2.48	0.47	

SRJ Wiring Diagram (Single-phase)

Terminal arrangement

Switch	Terminal No.	Degree of valve opening	
		Left limit	Right limit
RLS1	1-4	-----	-----
RLS2	5-6	-----	-----
LLS1	1-8	-----	-----
LLS2	9-10	-----	-----

: Contact ON : Contact OFF

13-14 : ON at right limit direction over-torque
 1-4 : OFF at right limit direction over-torque
 17-18 : ON at left limit direction over-torque
 1-8 : OFF at left limit direction over-torque
 31-32 : Heater power terminal

Direction of rotation

Single phase: Clockwise at R - (U), T - (X)
 Single phase: Counterclockwise at R - (V), T - (X)
 Direction of rotation refers to direction from the valve controller to the valve

Comment from Tomoe Valve:
 If the control power supply is DC, please refrain from using the thermal protector as the contacts may be fused. (Terminal No. 1)

Definition of codes

RLS1, RLS2 : Right directional rotation limit switch	M : Motor
LLS1, LLS2 : Left directional rotation limit switch	TH : Thermal protector
RTS1, RTS2 : Right directional rotation torque switch	H : Heater
LTS1, LTS2 : Left directional rotation torque switch	C : Condenser
	POT : Potentiometer (option)

SRJ Wiring Diagram (Single-phase 3-wire)

Terminal arrangement

Switch	Terminal No.	Degree of valve opening	
		Left limit	Right limit
RLS1	1-11	-----	-----
RLS2	5-6	-----	-----
LLS1	1-15	-----	-----
LLS2	9-10	-----	-----

: Contact ON : Contact OFF

13-14 : ON at right limit direction over-torque
 1-11 : OFF at right limit direction over-torque
 17-18 : ON at left limit direction over-torque
 1-15 : OFF at left limit direction over-torque
 31-32 : Heater power terminal
 27,28,29 : Potentiometer terminal

Direction of rotation

Single phase: Clockwise at R - 1, T - 11
 Single phase: Counterclockwise at R - 1, T - 15
 Direction of rotation refers to direction from the valve controller to the valve

Definition of codes

RLS1, RLS2 : Right directional rotation limit switch	M : Motor
LLS1, LLS2 : Left directional rotation limit switch	TH : Thermal protector
RTS1, RTS2 : Right directional rotation torque switch	H : Heater
LTS1, LTS2 : Left directional rotation torque switch	C : Condenser
	POT : Potentiometer (option)

- Actuator**
- New ELMY 41
 - New MICON ELMY II 41
 - PMK-SRF 4K
 - SRJ 4J
 - LTKD 4L
 - New T-DYNAMO 7E/7F/7G
 - TGA 3A
 - TG-S 3K/3U
 - 3C
 - Diaphragm 6X/6W/6Z/6A/6B
 - Hydraulic cylinder 3H
 - Manual Actuators 17/1J/2U/2I/2S/2G/2R

SRJ Wiring Diagram (Three-phase)

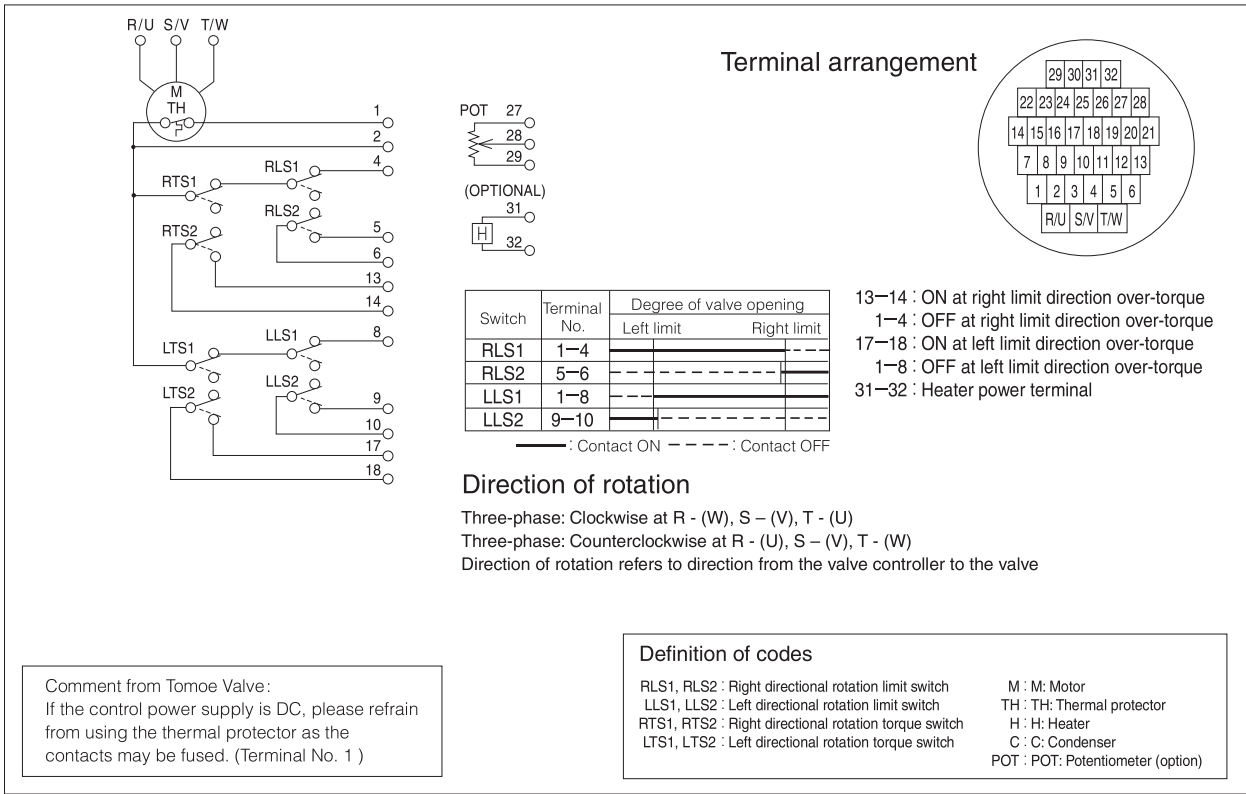

SRJ Wiring Diagram (Single-phase All terminals independent contact)

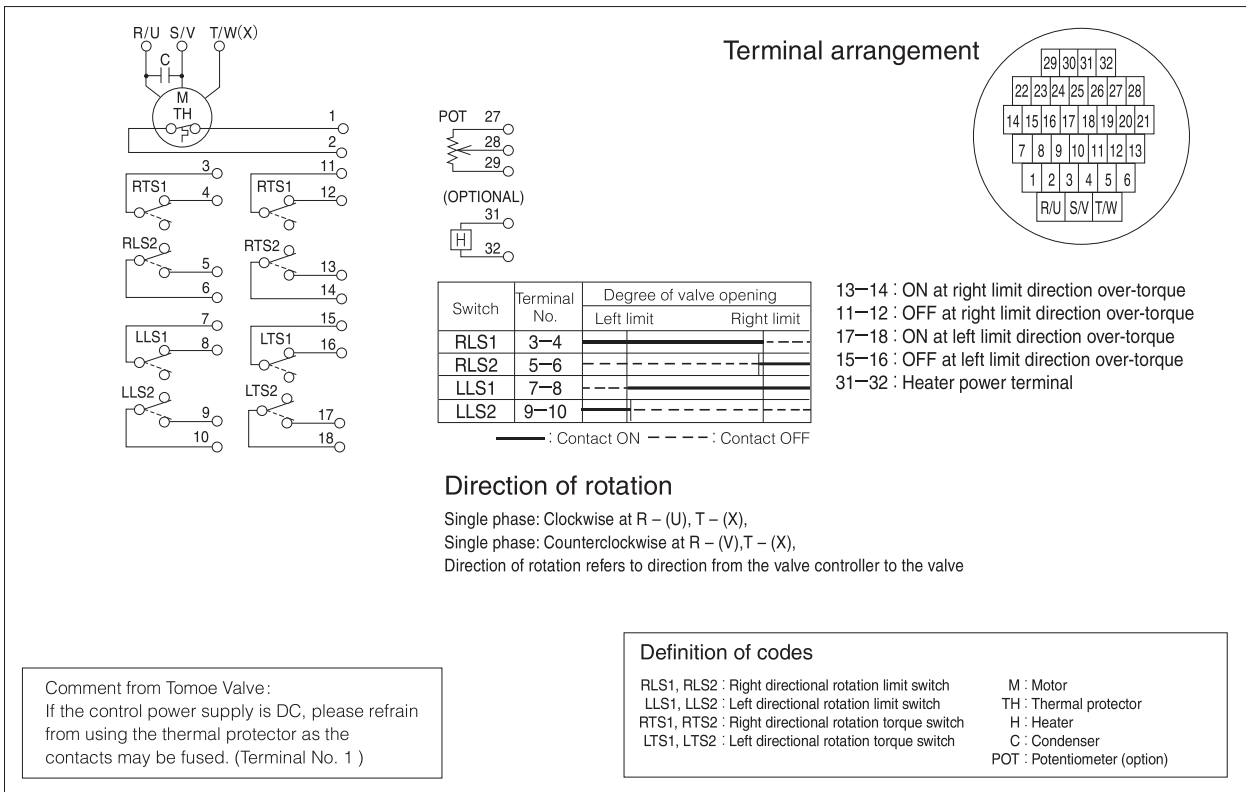

SRJ Wiring Diagram (Three-phase, All terminals independent contact)

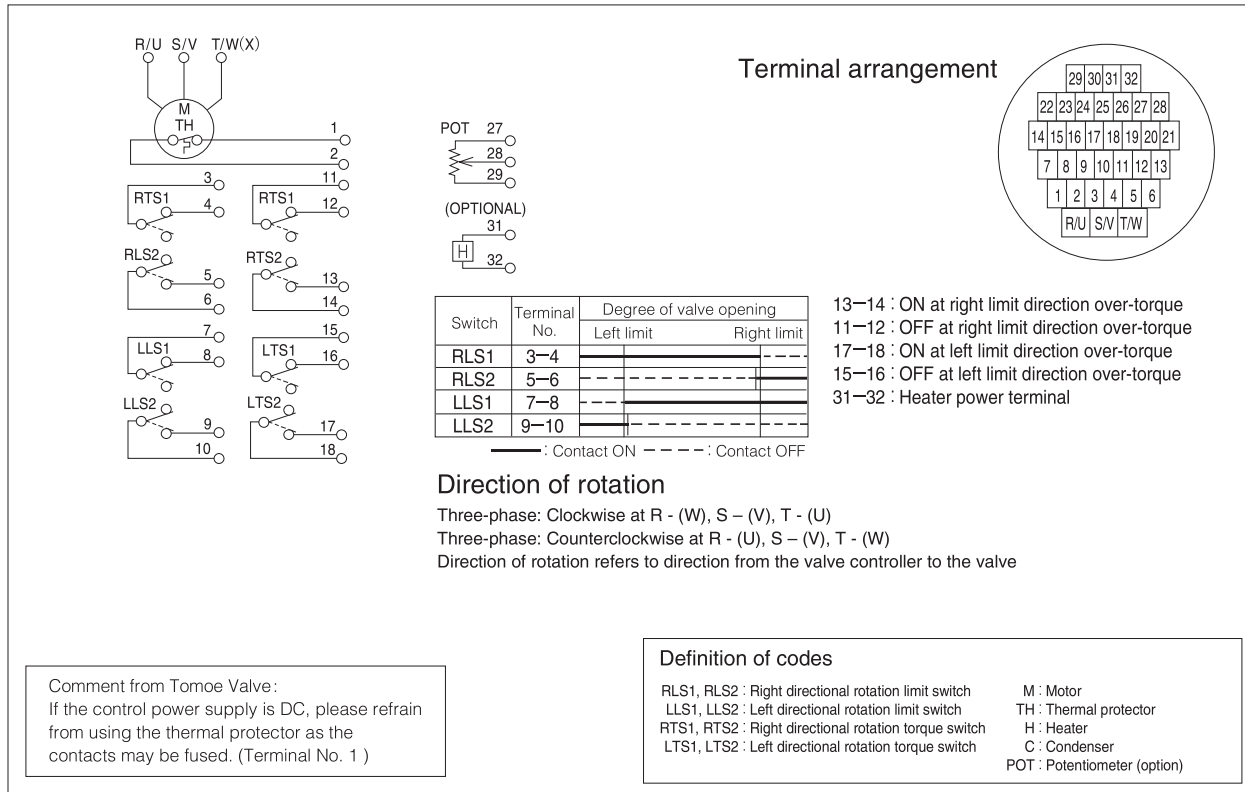

- Actuator**
- New ELMY 41**
- New MICON ELMY II 41**
- PMK-SRF 4K**
- SRJ 4J**
- LTKD 4L**
- New T-DYNAMO 7E/7F/7G**
- TGA 3A**
- TG-S 3K/3U**
- 3C**
- Diaphragm 6X/6W/6Z/6A/6B**
- Hydraulic cylinder 3H**
- Manual Actuators 17/1J/2U/2I/2S/2G/2R**

SRJ

SRJ Selection Chart

700 Series

Nominal size	mm	40	50	65	80	100	125	150	200	250	300	350	400	450
	inch	1 1/2	2	2 1/2	3	4	5	6	8	10	12	14	16	18
700G		SRJ-010					SRJ-020		SRJ-060			SRJ-1	SRJ-2	
704G / 722F		SRJ-010					SRJ-020		SRJ-060			SRJ-1	SRJ-2	
700S / 720F		SRJ-010					SRJ-020		SRJ-060			SRJ-1	SRJ-2	
732X												SRJ-2		
731P		SRJ-010					SRJ-020		SRJ-060		SRJ-1			
732P		SRJ-010					SRJ-020		SRJ-060	SRJ-1				

500 Series

Nominal size	mm	40	50	65	80	100	125	150	200	250	300	350	400	450
	inch	1 1/2	2	2 1/2	3	4	5	6	8	10	12	14	16	18
508V			SRJ-010		SRJ-010			SRJ-020	SRJ-060		SRJ-1	SRJ-2		
507V			SRJ-010		SRJ-010			SRJ-020		SRJ-060				

300 Series

Nominal size	mm	40	50	65	80	100	125	150	200	250	300	350	400	Nominal size	
	inch	1 1/2	2	2 1/2	3	4	5	6	8	10	12	14	16		
302Y	TL	SRJ-010					SRJ-020		SRJ-060		SRJ-1	SRJ-2			TL
	TH	SRJ-010			SRJ-020			SRJ-060			SRJ-2				TH
302A	T10				SRJ-010		SRJ-020		SRJ-060		SRJ-1	SRJ-2			Category A
	T20				SRJ-010	SRJ-020		SRJ-060		SRJ-1	SRJ-2			Category B	
304Y	T10	SRJ-010					SRJ-020		SRJ-060					T10	
	T20	SRJ-010				SRJ-020			SRJ-060					T20	
304A	T10				SRJ-010		SRJ-020		SRJ-060			SRJ-2		Category A	
	T20				SRJ-010		SRJ-020		SRJ-060			SRJ-2			Category B
					SRJ-010		SRJ-020		SRJ-060					Category C	

